



**NFPA and Level A
Total Encapsulated Suit**
Revision 1.4

CAUTION!

Most performance properties of the vapor protective ensemble or individual elements cannot be tested by the user in the field.

NOTICE!

This user information manual is to be removed only by the end user.

RM-4804

Table of Contents

Safety Information	Page 4
Level A and NFPA Requirements	Page 8
NFPA Instruction Requirements	
Safety and Health Program	Page 8
Cleaning Instructions, Marking Recommendations and Restrictions	Page 8
Maintenance and Repairs	Page 9
Frequency and Details of Inspection	Page 9
Test Procedures	Page 10
Recommended Training and Proper Use	Page 12
Recommended Undergarments, Visor Agents and Lubes	Page 13
Donning Procedure	Page 13
Safety Considerations and Limitations of Use	Page 13
Doffing Procedure	Page 14
Storage, Shelf Life, Decontamination	Page 14
Technical Data Package	
Chemical Resistance Guide	Page 15
Style Identification for Level A NFPA Complete Ensembles	Page 15
Specifications – Aluminized Overcovers	Page 15
Specifications – Level A Chemical Suit	Page 16
Chemical Suit Size Charts, Sizing and Adjustment Procedures	Page 17
Warnings and Limitations	Page 18
Quarterly Inspection and Air Pressure Test Chart	Page 20
Level A Inspection Checklist	Page 21
Test Kit Part Numbers	Page 22
Certification Letter	Page 23

►3

Finding Your Way Around

Each section in a given chapter begins with an overview of the topic or task discussed. In addition, icons are shown where a topic is important and needs particular attention.



Information that follows this icon provides a warning. Serious injury or death could result if procedures are not followed.



Information that follows this icon includes helpful tips, procedures or references to help you avoid problems or save time

Level A Chemical Suit and NFPA Complete Ensembles

WARNING:

There are uses and chemicals for which Lakeland suits are not appropriate. The suit will perform as designed only if it is used and serviced according to the instructions. **It is the sole responsibility of the user to select a suit and accessories such as chemically resistant boots, gloves, and other PPE not provided by us, which is appropriate for the intended use and which meets all national, state and local health and safety regulations.**

Lakeland does not warrant that this suit meets the requirements of any safety code of any state, municipality or other jurisdiction.

- 4 Lakeland's only warranty is that for a period of 90 days after the delivery of a Lakeland suit that the suit is free from defects in materials and workmanship when used in accordance with the instructions contained in this manual.

The purchaser and all suit users must promptly notify Lakeland of any claim, whether based on contract, negligence, strict liability, or otherwise.

This manual gives a general description of Lakeland's Level A chemical suit and NFPA complete ensembles. While some uses and performance capabilities are described, under no circumstances should the product be used except by qualified, trained personnel in accordance with all OSHA training and other NFPA and NIOSH regulations, and not until the instructions, labels, or other literature accompanying this product have been carefully read and understood and the precautions set forth therein followed. Only they contain the complete and detailed information concerning this product. Any person who reads this manual and is still uncertain about how to safely operate or service this suit should contact Lakeland Industries for more information at 1-800-645-9291.

All Lakeland level A, B and C chemical and NFPA ensembles are manufactured and sold by Lakeland's Chemical Clothing Divisions, a wholly owned division of Lakeland Industries, Inc

WARRANTY:

The following is made in lieu of all warranties expressed or implied including without limitation implied warranties or merchantability or fitness for a particular purpose: seller's only obligation shall be to replace such products proved to be defective because of workmanship. This warranty does not extend to raw materials and components supplied to Lakeland or any of its subsidiaries or divisions. Seller shall not be liable for injury, loss or damage, direct or consequential, arising out of the use or inability to use the product. Before using, user shall be solely responsible for determining the suitability of the product for its intended use and user assumes all risk and liability whatsoever in connection therewith. Safety and permeation data for Lakeland protective clothing is available upon request. As in almost all instances, we do not know and cannot contact end users of our products, it is therefore, incumbent upon safety distributors to distribute to the end users both Lakeland's and the fabric manufacturer's safety and permeation data and other safety and use information as updated. Such data does not attempt to address all of the safety issues associated with improper selection of a garment for the foreseeable application, use without adequate training, disregard of any warnings and instructions supplied by us or the fabric manufacturer and failure to maintain and inspect the garments. Users should discontinue using our garments immediately if they become torn or abraded to avoid potential exposure to hazardous chemicals. Lakeland and its divisions protective garments are intended to be used only in conjunction with an organized safety protection program, the requirements of all regulations promulgated by the Environmental Protection Agency (EPA), and the requirements of OSHA Safety and Health Standard 29 CFR 1910 and other OSHA regulations such as section 1910 et.seq., available from the National Fire Protection Association (NFPA), The American Society for Testing and Materials (ASTM), and the US Coast Guard or the Department of Defense. The foregoing may not be changed except by an agreement signed by an officer of the seller. In all events, we make no warranty of any kind whatsoever, express or implied, and all implied warranties of merchantability and fitness for a particular purpose are hereby disclaimed by us and excluded from any contract. For more information visit us at www.lakeland.com



SAFETY CONSIDERATIONS

Be sure to read and follow the information in this manual and all applicable federal, state and local occupation safety and health statutes. Serious injury or death may occur from improper use of this garment. Proper use must be consistent with NFPA 1500, Standard on Fire Department Occupational Safety and Health Program, and 29 CFR 1910.132.

This garment is not suitable for use in all situations and environments with all chemical and hazardous materials. All decisions regarding the choice of chemical protective clothing and its use must be made by trained and qualified safety professionals. It is the user's responsibility to determine the level of exposure and the proper personal protective equipment (PPE) needed. Most performance properties cannot be tested by the users in the field. Refer to the Lakeland Permeation Guide for chemicals specific to your situation.

If any of the following symptoms develop during use of this garment, immediately leave the contaminated area, undergo field decontamination (if exposed), and doff the garment:

- Fever
- Difficulty breathing
- Nausea
- Excessive Tiredness
- Dizziness
- Numbness
- Any unusual odor or taste
- Eye or skin irritation
- Narrowing or dimming of vision
- Claustrophobia
- Loss of balance or orientation



WEARER QUALIFICATIONS

This garment should be worn only by persons who are properly trained in the usage of this garment and who are in good physical condition to perform tasks involving the use of this garment. Consult a physician before donning a suit to ensure you are capable of wearing this garment under the expected work conditions and environment.



ADDITIONAL EQUIPMENT

To help protect the wearer and to perform as intended, this chemical protective garment must be worn with several additional items of personal protective equipment (PPE). At a minimum the following components must be worn with the enclosed chemical protective garment:



NFPA COMPLIANT GARMENTS (NFPA 1991 AND VAPOR-PROTECTIVE ENSEMBLES)

- Separate, user-supplied, full-face respiratory protection such as: 1) an open circuit, self-contained breathing apparatus (SCBA) which is also certified as compliant with NFPA 1981 Standard on Open-Circuit Self-Contained Breathing Apparatus for Fire Service, 2) an external breathing air supply (air line system with pass-through and escape bottle) or 3) a closed-circuit, self-contained breathing apparatus (rebreather).

Only the STEPO REBREATHING UNIT is approved for use for Lakeland Level A chemical suits and only when the proper installation of the special exhalation valve designed for the rebreather is in place.

Powered air-purifying respirators (PAPR) cannot be worn with totally encapsulating vapor protective (Level A) or liquid protective (Level B) garments.

The next updates to these NFPA standards will most likely require NIOSH-certified, CBRNE (chemical, biological, radiological, nuclear, explosive) respirators.

- NFPA 1991 compliant Lakeland chemical protective ensembles must incorporate a separate over-cover to provide required abrasion resistance, puncture resistance, and protection from direct flame impingement.
- Separate, user-supplied protective footwear specified in the Technical Data Package of this document. NFPA compliant Lakeland chemical protective garments include attached socks made of garment material. These socks must be worn inside the protective footwear. These socks are not suitable as outer footwear. ➤5
- NFPA compliant Lakeland chemical protective garments are equipped with outer boot covers to prevent liquid pooling inside the boot. After the garment is donned, the boots are donned and the outer cover is pulled down over the upper portion of the boot.
- NFPA compliant Lakeland chemical protective garments include attached chemical protective gloves. Separate, cut-resistant outer gloves are required on NFPA 1991 compliant garments.

NFPA compliant garments utilize multiple chemical resistant gloves to achieve the chemical barrier and physical performance requirements of the standard. All chemical gloves must be present in compliant ensembles. It is the user's responsibility to verify that the glove will provide adequate barrier and physical performance for the intended task.

- User-supplied head protection.



NON-COMPLIANT GARMENTS (LEVEL A AND LIQUID-SPLASH PROTECTIVE)

- Separate, user-supplied, full-face respiratory protection such as: 1) an open circuit, self-contained breathing apparatus (SCBA), 2) an external breathing air supply (air line system with garment pass-through and escape bottle) or 3) a closed-circuit, self-contained breathing apparatus (rebreather).

Air-purifying respirators (APR) cannot be worn with totally-encapsulating vapor protective (Level A) or liquid protective (Level B) ensembles. Air-purifying respirators (APR) can be worn under protective hoods that extend below the clavicle.

Powered air-purifying respirators (PAPR) cannot be worn with totally encapsulating vapor protective (Level A) or liquid protective (Level B) garments. PAPR's can be worn under separate protective hoods, if the configuration provides adequate ventilation at the intake of the unit and the unit is adequately protected from contamination.

- Separate, user-supplied, protective footwear. Many, but not all, Lakeland chemical protective garments have socks made of garment material. These socks must be worn inside the protective footwear. These socks are not suitable as outer footwear.
- These garments may also be equipped with outer boot covers to prevent liquid pooling inside the boot. After

the garment is donned, the boots are donned and the outer cover is pulled down over the upper portion of the boot.

The cuffs of Lakeland chemical protective garments that do not have socks should be worn over the upper portion of the user's boot to prevent run-off and pooling of liquid within the boot. Adhesive taping of the garment cuff to the boot does not provide a leakproof seal. Taping should only be used to hold the garment cuff in position over the boot. If a leak-proof seal is required, then garments with sock and boot covers should be selected.

- The use of footwear with toe crush protection, cut-resistant, and slip-resistant soles is recommended.
- The use of separate cut-resistant gloves may also be considered.
- Level A, vapor-protective Lakeland chemical protective garments are provided with attached chemical protective gloves.

Liquid-protective Lakeland chemical protective garments may or may not be equipped with attached chemical protective gloves. If not attached, user-supplied chemical protective gloves should be worn with the sleeve of the garment over the gauntlet of the glove. Adhesive taping of the glove to sleeve interface does not provide a leakproof seal. Taping should only be used to hold the sleeve in position over the glove gauntlet. If a leak-proof seal between the glove and sleeve is required, then a garment with attached gloves should be selected.

Some Lakeland chemical protective garments utilize multiple chemical-resistant gloves to achieve the chemical barrier and physical performance requirements. Removal of one of the glove layers may compromise chemical barrier or glove durability.

It is the user's responsibility to verify that the glove and the glove/sleeve interface will provide adequate barrier and physical performance for the intended task.

- User-supplied head protection.

Additional personal protective equipment may be required. Consult with a trained and experienced safety professional to determine the additional PPE components required for your specific situation.

- Hearing protection may be required due to high levels of external noise or high noise levels generated by supplied air systems.
- Other protective equipment may be warranted based on the situation to deal with additional hazards which may include, but are not limited to:

- _ Flammable or Explosive Environment
- _ Decontamination
- _ Extreme Heat (Heat Stress)
- _ Extreme Cold (Hypothermia)
- _ Asphyxiating Atmosphere
- _ Physical Hazards (Sharps, Puncture, Rough Surfaces, Falling Debris)
- _ Slipping or falling
- _ Visibility - of wearer & by wearer
- _ Communications

- Before use, you must read "warranty information" and "warnings and limitations" at the end of this manual.

Warranty Card

Style Number: _____

Serial Number: _____

Purchased From: _____

Purchase Date: _____

End User Name: _____

Product Ship To: _____

Street _____

City: _____ State: _____

Zip: _____ Phone: _____

Lot Number(s): _____

Pressure Test Results: _____

Please rate the following:

	Excellent	Good	Fair	Poor
Quality of construction	<input type="checkbox"/>	<input type="checkbox"/>	<input type="checkbox"/>	<input type="checkbox"/>
Value versus price paid	<input type="checkbox"/>	<input type="checkbox"/>	<input type="checkbox"/>	<input type="checkbox"/>
Comfort and fit	<input type="checkbox"/>	<input type="checkbox"/>	<input type="checkbox"/>	<input type="checkbox"/>
Promptness of delivery	<input type="checkbox"/>	<input type="checkbox"/>	<input type="checkbox"/>	<input type="checkbox"/>
Accuracy of order	<input type="checkbox"/>	<input type="checkbox"/>	<input type="checkbox"/>	<input type="checkbox"/>
Service given by distributor	<input type="checkbox"/>	<input type="checkbox"/>	<input type="checkbox"/>	<input type="checkbox"/>
Will you purchase through the same distributor again?			<input type="checkbox"/> Yes	<input type="checkbox"/> No
When you purchase protective clothing again, will you ask for the Lakeland brand?			<input type="checkbox"/> Yes	<input type="checkbox"/> No
Comments: _____				

Level A and NFPA Requirements

Level A represents the greatest danger of respiratory, eye or skin damage from hazardous vapors, gases, particulates, sudden splash, immersion or contact with hazardous materials. It calls for total encapsulation in a vapor-proof chemical suit with self contained breathing apparatus (SCBA) and appropriate accessories.

Level A Conditions:

1. Unknown Hazards
2. Immediately Dangerous to Life Health (IDLH) Atmospheres
3. Atmosphere contains less than 19.5% oxygen
4. Percutaneous Chemicals
- 8 5. Vapors/Liquids Injurious to Skin

Personnel Protection Equipment Required:

1. Self Contained Breathing Apparatus (SCBA), or positive pressure supplied air respirator with SCBA (NIOSH approved)
2. Fully encapsulating chemical resistant suit
3. Coveralls*
4. Long underwear*
5. Gloves-(outer), chemical resistant
Gloves-(inner), chemical resistant
6. Boots-chemical resistant, steel toe and shank
7. Hard hat* (under suit)
8. Disposable protective suit, gloves, and boots*
9. Two-way radio communication* (intrinsically safe)
10. An air leakage test to ensure suit is vapor proof.

*Optional

In addition to meeting all OSHA Level A requirements, NFPA imposes even higher levels of protection on NFPA Complete Ensembles. The same conditions exist as Level A with additions to the personal protective equipment list.

1. Permeation test done on not only suit material, but on gloves and seams.
2. Flammability test.
3. Special labeling requirements.



See "Specifications – Level A Chemical Suit" section in this manual.

Safety and Health Program

An effective and comprehensive safety and health program is essential in reducing work-related injuries and illnesses and in maintaining a safe and healthful work environment. The standard, therefore, requires each employer to develop and implement a written safety and health program that identifies, evaluates, and controls safety and health hazards and provides emergency response procedures for each hazardous waste site or treatment, storage, and disposal facility. The program must be periodically updated and made available to all affected employees, contractors and subcontractors. The employer also must inform contractors and subcontractors and employees of any identifiable health hazards or potential fire or explosion hazards before they enter the worksite. This written program must include specific and detailed information on the following topics:

1. An organizational workplan.
2. Site evaluation and control.
3. A site-specific program.
4. Information and training program.
5. Personal protective equipment program.
6. Monitoring.
7. Medical surveillance program.
8. Decontamination procedures.
9. Emergency response program.

Cleaning and Marking the Suit



Cleaning procedures are not an acceptable procedure for decontamination. The user should develop and implement a decontamination procedure for each of the chemicals to which the suit has been exposed.

After decontamination, wash down the suit with a solution of low sudsing powered detergent and water. A product like *Tide*® would be acceptable. Use warm to moderately hot water to cleanse suit inside and out. Wash off solution according to federal, state, and local pollution regulations. This may mean using a catch basin, such as a wading pool. Hang dry at room temperature.



Warning! Do not use garments that are not thoroughly cleaned and dried.

Marking Recommendations and Restrictions

Marking can be made on either your aluminized overcover or Level A suit by using a black laundry marker.

Maintenance and Repairs

Upon receipt, the Level A suit should be tested to insure that no damage has occurred during shipment. After that, the Level A suit should be tested after every use and at least annually, whether it is used or not. If the Level A suit fails the test, see "Testing" and "Returns" for more information. In addition to testing, the Level A suit must be inspected after every use and at least annually. A Level A Inspection Checklist has been provided at the back of this manual to assist in the inspection.

Check the zipper for overall condition, worn or damaged teeth, and ease of operation. Lubricate zipper lightly with paraffin, which is readily available in most grocery stores. Paraffin should be applied lightly to the inner and outer elements. After cycling the zipper several times, the excess flakes should be removed. Do not use a sticky lubricant which could gather and hold particles of dirt, grease, or contaminant.

Repairs

The gloves on the Level A Level A suit can be replaced by the end user while in the field. See "Glove Replacements" for instructions. Any other modifications or repairs must be done only by Lakeland personnel.

Warning: All NFPA modifications or repairs must be done by Lakeland personnel.

Do not send a contaminated suit to Lakeland! Suits must be decontaminated and cleaned before return or they will be sent back without inspection of suit.

Returns

When returning a suit to Lakeland, follow the procedures listed below.

1. Attach the following to the side of the return shipping container:
 - If the suit has not been used, a letter which states that the suit is in a new and unused condition.
 - If the suit has been used**, a copy of the decontamination document, listing the procedures used, and a statement indicating that the suit contains no detectable residual contamination.
2. A Return Goods Authorization number must be on each container returned. This number will be given out to you by Lakeland's Customer Service Department.
3. The Level A Suit should be shipped folded in a case or box.
4. The suit should not be pressurized during shipment.

Frequency and Details of Inspection

Inspection Record

Before using the suit, look at the inspection record and check:

1. The date that the suit was last decontaminated.
2. The level of decontamination obtained.
3. The date when the suit was cleaned and sanitized.
4. The date that the suit was tested for leakage resistance with the Lakeland Test Kit (part number 0010).
5. The suit must be checked with Lakeland's Test Kit at least annually.
6. The date that the person making the inspection signed-off, indicating that the suit is ready for reuse. See "Annual Inspection and Air Pressure Test Chart".

Suit Physical Inspection

1. Look at the suit closely, checking for missing or damaged parts.
2. Look for holes and tears in the fabric.
3. Look for wear or abrasion that could let a chemical penetrate the suit. Inspect all seams thoroughly.
4. Check the gloves and boots for tears or abrasions. Pull on the boots and gloves to make sure that they are firmly attached.
5. Check the lens for cracks or deep scratches.
6. Check that the zipper has been lubricated; see section entitled "Maintenance and Repairs".

Inspect the breathing apparatus according to the manufacturer's instructions. Check the pressure gauge to be sure that the cylinder is fully charged.

If you find any signs of wear, damaged, or missing parts, do not use the suit!

Retirement and Disposal Criteria

Use department procedures for disposal of suit. Lakeland Level A suits can be incinerated.

Test Procedures



**REFER TO THE MANUFACTURERS INSTRUCTIONS
THAT COME WITH YOUR TEST KIT FOR PROPER
PROCEDURES TO PERFORM A PRESSURE TEST**

Lakeland Test Kits

00200 – Universal Test Kit

00010 – Basic Test Kit*

00011 – Basic NFPA Ensemble Test Kit*

➤10 00500 – Totally Automatic Test Kit

*Refer to the Lakeland website for proper test kit instructions
www.lakeland.com

Component Assembly for Testing Procedures

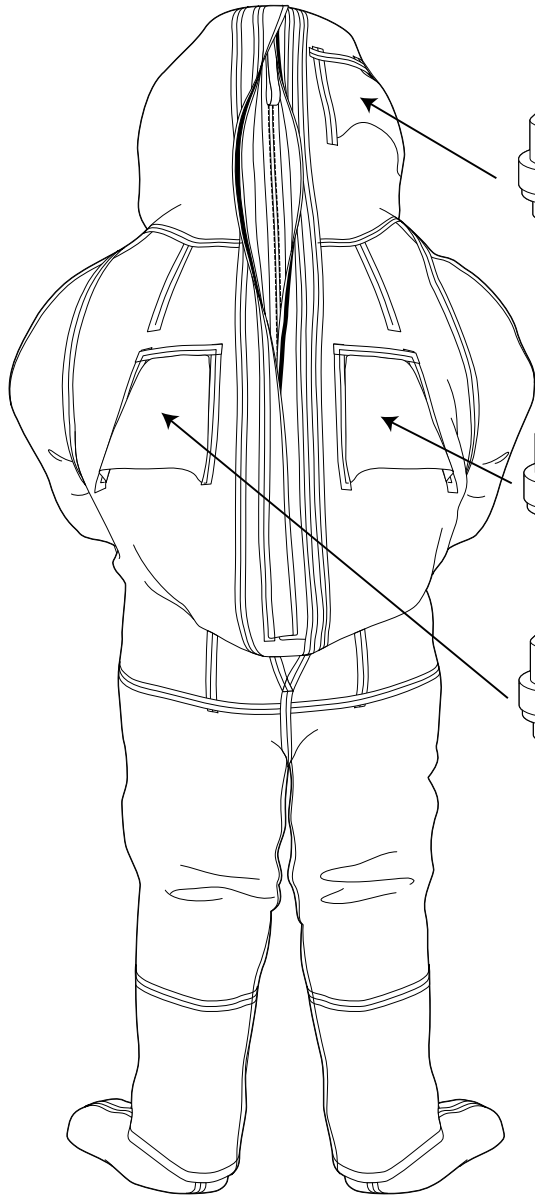

Twist lock with male adapter, hose assembly and brass tee. Twist lock goes into the exhaust valve at the head. Brass tee connects to your air source. **Use only regulated air! Do not use more than 125 psi to connect to test unit!**

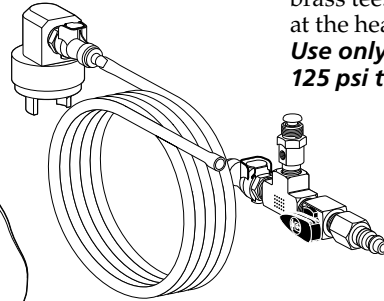

Insert twist lock plug adapter into the third exhaust valve located on the back right body (If your garment is a NFPA complete ensemble) to serve as a plug to prevent air from escaping.

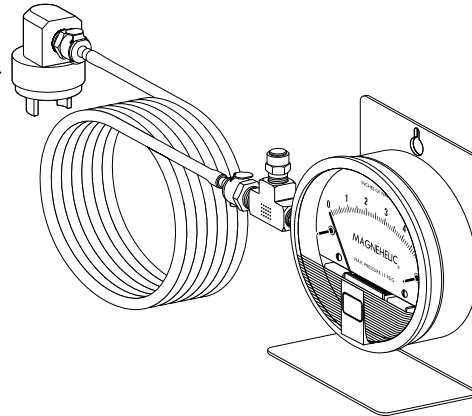
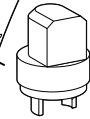

Twist lock with female adapter, hose assembly and gauge. Twist lock goes into the exhaust valve at the left.

Glove Replacement Guides

Instructions for Ring and Clamp Assembly Removal

1. Turn sleeve inside out.
2. Remove tape and rubber band over clamp at top of glove.
3. Using a hex socket or ratchet, loosen screw on glove clamp, remove clamp. Do not use a screwdriver to loosen clamp, as screwdriver may slip and damage suit.
4. Remove rubber band.
5. Pull glove assembly out of sleeve.

Ring and Clamp Assembly Installation

1. Sleeve should be inside out.
2. Insert PVC ring in glove so that 2 inches of the glove is above top of ring.

3. Place glove in sleeve, fingers toward you and middle finger in line with shoulder seam. Pull until tight.
4. Place elastic band centered on line with PVC ring.
5. Center glove clamp on rubber band, using a hex socket driver or ratchet to tighten screw. Tighten clamp. Do not use a screwdriver to tighten screw, as screwdriver may slip and damage suit.
6. Turn the 2" glove overlap over clamp. Place wide rubber band over clamp.
7. Securely wrap area over PVC ring and clamp with flexible tape.
8. Turn suit sleeve right side out.

Instructions for Quick Disconnect Assembly Removal

1. Remove outer glove assembly by unlocking the Quick Disconnect System.
2. Remove tape over clamp at the top of glove.
3. Using a hex driver, loosen screw on glove clamp; and remove clamp. Do not use a screwdriver to loosen clamp, as screwdriver may slip and damage suit. Remove outer gloves.

Instructions for Quick Disconnect Assembly Installation

1. Sleeve should be inside out.
2. Insert Silvershield® glove through male glove ring, turn at least 3 inches of the glove edge back over the edge of the glove ring.
- ▶12 3. Insert the male glove ring through the suit opening down to the sleeve opening.
4. Place the clamp 3/8" from the edge of the glove ring, and tighten firmly in place using a hex driver.



The locking pin must be centered with the middle finger of the glove and the sleeve seam to insure proper alignment.

5. Place a 7/8" rubber band over the clamp to prevent it from puncturing the suit, cover the rubber band with at least 3 rounds of black electrical tape.
6. Pull sleeve back through suit and straighten.
7. Insert female glove ring (grooved side first) into outer glove so that the glove extends 3" past the groove in the ring. Place 5/8" rubber band over cuff clamp into the groove in the ring and tighten using a hex driver. Do not use a screwdriver, as screwdriver may slip and damage suit.
8. Cover the clamp with at least three rounds of black electrical tape to prevent clamp from damaging the suit.
9. Place a 5/8" wide rubber band between glove and clamp to prevent damage to glove. Place clamp in center of groove on top of rubber band.



Female notch in glove ring must be aligned with the thumb of the outer glove, this will allow the two glove system to align correctly and discourage loosen of the assembly due to movement in the wrist area.

Removal

1. Remove outer glove assembly by unlocking the Quick Disconnect System.
2. Remove tape over clamp at the top of glove.
3. Using a hex driver, loosen screw on glove clamp; and remove clamp. Do not use a screwdriver to loosen clamp, as screwdriver may slip and damage suit. Remove outer gloves.

Recommended Training & Proper Use

Employers are required to develop and implement a program to inform workers (including contractors and subcontractors) performing hazardous waste operations of the level and degree of exposure they are likely to encounter.

Employers are also required to develop and implement procedures for introducing effective new technologies that provide improved worker protection in hazardous waste operations. Examples include foams, absorbents, neutralizers, etc.

Training makes workers aware of the potential hazards they may encounter and provides the necessary knowledge and skills to perform their work with minimal risk to their safety and health. The employer must develop a training program for all employees exposed to safety and health hazards when working with hazardous chemicals or working in hazardous waste operations. Both supervisors and workers must be trained to recognize and prevent hazards; to select, care for; and use respirators properly as well as other types of personal protective equipment; to understand engineering controls and their use; to proper decontamination procedures; to understand the emergency response plan, medical surveillance requirements, confined space entry procedures, spill containment program, and any appropriate work practices. Workers must also know the names of personnel and their alternates responsible for site safety and health.

Employees at all sites must not perform any work in or around hazardous waste operations or sites unless they have been trained to the level required by their job function and responsibility and have been certified by their instructor as having the necessary training. All emergency responders must receive refresher training sufficient to maintain or demonstrate competency annually. Employee training requirements are further defined by the nature of the work (e.g., temporary emergency response personnel, firefighters, safety officers, Hazmat personnel, incident commanders, etc.) These requirements may include recognizing and knowing the hazardous materials and their risks, knowing how to select and use appropriate personal protective equipment, and knowing the appropriate control, containment, or confinement procedures and how to implement them. The specific training and competency requirements for each personal category are explained fully in the final rule (54 FR 42:9294, March 6, 1989).



It is your responsibility, as a user of this Level A Total Encapsulated Suit, to be aware of and comply with all phases of your employer's safety and health program, including training. Failure to do so could lead to an accident which may result in severe personal injury or death.

"Proper Use" is consistent with NFPA 1500, "Standard on Fire Department Occupational Safety and Health Program, 29 CFR 1910.132." You can obtain a copy of this NFPA standard on the world wide web at "www.nfpa.org".

Recommended Undergarments and Visor Agents

Wear cotton underwear and socks to help absorb perspiration. Coveralls made from flame resistant synthetic materials, such as Nomex®, offered by Lakeland Industries, are recommended, especially if exposure to flash-fire is a concern. Coveralls should have sleeves that can be closed tightly and legs that can be tucked into the socks. If the Level A suit is to be worn in a cold environment, wear thermal underwear to help stay warm. Under extreme conditions, the lens may fog up. Carry a clean cloth with you to wipe the lens from the inside. Anti-fog agents can be purchased from most local stores. Lakeland Industries does not sell or apply any agents to the suit lens.



For zipper lubes see “Maintenance and Repairs” for more information.

Donning Procedure



Good safety practices require an assistant to help you don and doff the suit. This is easier and quicker, and you will avoid stumbling or tripping which may result in personal injury or damage to the suit.

Follow these steps in putting on the suit:

1. Make sure the suit has been visually inspected, air pressure tested and is free from defects. Also make sure the correct suit has been selected for the intended use.
2. Underclothing should be worn under the chemical suit. As a minimum, a long sleeve shirt and long pants or “long underwear” are recommended.
3. Remove all personal affects which might result in damage to the suit (e.g. pens, badges, jewelry, etc.).
4. Remove shoes. Most boots don’t allow street shoes. Lakeland’s NFPA approved boots do not.
5. Tuck pant cuff into socks to make donning of suit legs and sock boot easier.
6. If using a SCBA (Self Contained Breathing Apparatus), check the level of air, complete all connections, make all adjustments in accordance with the manufacturer’s procedures. Do not put the face piece on, yet, unless required by the design of the SCBA.
7. While seated, place both legs into the suit. Stand up and attach the internal waist belt. Belt is intended to help adjust the fit of the suit.
8. Turn on the air supply, put on facepiece, and make sure air supply system is working properly.
9. Place arms and head inside the suit, close the zipper, then velcro shut the fly over the top of the zipper.
10. The person assisting should check to make certain the zipper covers are completely closed, all airline connections are tight, and suit appears to be working properly.

Safety Considerations



Like any piece of complex equipment, the Level A suit will perform as designed only if used and serviced according to Lakeland’s instructions. All individuals who have or will have the responsibility for using the Level A suit must read these precautions carefully and understand them. Failure to do so may result in severe personal injury or death.

1. Avoid direct flame contact. Do not use the Level A suit near a fire or open flame. The Level A material will melt.
2. Do not wear a suit without breathable air. An air supply is **mandatory** to prevent suffocation. An air-line alone is prohibited by OSHA regulations in IDLH atmospheres.
3. Do not use oxygen cylinder or oxygen generating breathing apparatus while wearing a Level A suit. A severe fire hazard could result.
4. Never work alone in hazardous areas. Always work with another person and have at least one person on standby with equal protective equipment.
5. Do not pull on air supply hose as a retrieval device. To do so may cause the air-supply hose to tear out of the suit and expose the wearer.
6. Avoid continuous exposure. Do not expose the suit to a constant liquid splash or deluge, or wade through liquid pools on purpose.
7. Prevent heat stress. Workers who wear total-encapsulating suits must be in good physical condition. Consult a medical doctor before donning Level A suit to be sure you are capable of wearing it under expected use conditions. The wearer can take several steps which may prevent heat stress, such as wearing an ice-vest, feeding the suit with body-cooling air, and taking frequent rest periods during the work session.
8. Leave the “Hot Zone” **immediately** if you experience these symptoms; fever, nausea, dizziness, eye irritation, difficulty in breathing, becoming fatigued or any unusual order or taste.

Doffing Procedure



The person assisting in the doffing procedure should be wearing the appropriate attire selected by Qualified Safety Personnel.

1. The person assisting should open the zipper flaps by separating the velcro attached to the fly and open the zipper by pulling the zipper tab at the opening of the zipper.
2. The user should pull their arms back into the body of the suit, remove their hard hat, and hand hat to the assistant (this will prevent the assistant from touching the inner suit with their gloves that may be wet or contaminated).
3. Carefully remove the head and arms from the suit.
- 14 4. Loosen the air supply mask (allow the mask to hang around the neck until the air supply has been cut off. Remove the air system per the instructions provided with that particular system.
5. Loosen the suit belt and allow suit to fall. Assume a sitting position for stability. The assistant should remove the outer boots and hold the bottom of each leg to allow the user to remove legs from the suit more easily.

Storage, Shelf Life & Decontamination

Recommended Storage Practices

1. Store the Level A or NFPA Complete Ensemble in a clean, dry location, away from direct sunlight.
2. Suit should be stored laying flat, if possible.
3. Store the suit with zipper completely open.
4. At least annually perform inspection with checklist at the back of this manual, and perform the suit pressure test using the instructions under *"How To Use Test Equipment And Air Pressure Testing."*
5. NFPA complete ensembles are to be stored the same as a Level A suit.
6. Suits can be stored in their original carry-bags, or on a hanger.

Shelf Life

Chemical suits contain components made from various polymer or rubber materials for which there is no specific life data currently available. Based on the physical condition of the suit, it is recommended that downgrading the suit to *"Training Use Only"* be considered after five years. If this is done; each suit will need to be visually marked on the outer side *"For Training Use Only"*, so that all personnel will notice it has been down graded.

Decontamination – Chemical

Standard 1910.120 states that *"a decontamination procedure shall be developed, communicated to employees and implemented before any employees or equipment may enter areas on site where potential for exposure to hazardous substances exists"*.

The Environmental Protection Agency considers decontamination to be a complex operation that requires

a detailed plan of procedures. Actual decontamination procedures must be developed by those with full information on the type and level of the contaminant. Consult the Materials Safety Data Sheet for the hazardous substance you are working with.

After decontamination, suits may be hand washed using warm water and a mild detergent (see *"Cleaning Instructions"* in this manual). Appropriate equipment should be worn during these activities to prevent contact with any residual contamination. After washing, suits should be rinsed well with warm water and hung away from intense heat or sunlight to dry. Before reuse, a qualified health professional must determine that an adequate level of decontamination has been achieved.

Level A suits are economically priced limited-use garments, and **not** designed for multiple wash and decontamination. Chemical suits which become contaminated with toxic chemicals or show signs of physical wear, (see *"Maintenance And Repairs"*), should be retired or disposed of in a safe manner.

Decontamination-Biological

At the scene, place contaminated garments inside a leak-proof container and marked as *"Biological Contaminated."* These garments must be destroyed by a Certified Waste Disposal Company. **DO NOT** attempt to decontaminate any garments that have come in contact with any Biological Threat.

Chemical Resistance Guide

A protective garment must resist hazardous chemical attack from three different routes of entry: Permeation, Penetration and Degradation.

Permeation describes a process by which chemicals migrate through a material. It involves chemical solubility in a material and the ability for chemicals to “diffuse” through the material as a liquid, gas, or vapor. Measuring permeation is important because chemicals may penetrate protective materials without visible effects. Many of today’s chemicals are toxic in vapor form, through skin absorption or inhalation. The Level A material resists permeation of these chemical vapors, depending on the type of challenge chemical. Method F739 provides flexibility for choosing different test hardware and conditions while specifying procedures.

Penetration occurs when a chemical enters the suit through a physical imperfection, such as a damaged seam or zipper, a tear, a pinhole, a loose glove, boot, or lens.

Suits must be leak-tested in the field to ensure their penetration resistance. Simple bubble-indicating leak tests, without measuring pressure-drop over time, are not practical.

The Lakeland Test Kit (part number 00010) measures penetration resistance by indicating pressure-drop over time. It permits the user to inflate the suit with an SCBA, measure the pressure put into the suit, and the rate at which the pressure may drop.

Degradation takes place when a chemical degrades one or more of the suit’s physical properties, such as material thickness, color, tear resistance, abrasion resistance, and so forth. Such a physical change may not necessarily affect the material’s permeation resistance. However just the opposite is also possible. A challenge chemical could permeate the garment material almost immediately without changing its physical appearance at all. Tests were performed under laboratory conditions-not actual workplace conditions. They address breakthrough characteristics and do not account for other performance characteristics. They are not, in and of themselves, recommendations.

Lakeland chemical suits are designed to be worn over regular work clothing, and are not designed to protect from all hazards in the work place. Additional equipment such as protective eyewear, protective boots, additional gloves, hard hats, cooling systems, communications systems, etc. may be required and should be selected by a safety professional.

Lakeland Industries, Inc. cannot guarantee that any Level A suits is applicable to your particular situation, or assume responsibility for use thereof, because of such unknown variables as nature of work, type of exposure, concentration of exposure, etc.

Style Identification

TK645- A Front Entry Level A Level A Chemical Suit (with) A Front Entry Aluminized Glass Overcover and NFPA approved Hazmat Boots.

TK645W- A Front Entry Level A Level A Chemical Suit (with) A Front Entry Aluminized Glass Overcover and NFPA approved Hazmat Boots. Wide-view lens.

TK655- A Rear Entry Level A Level A Chemical Suit (with) A Rear Entry Aluminized Glass Overcover and NFPA approved Hazmat Boots.

TK655W- A Rear Entry Level A Level A Chemical Suit (with) A Rear Entry Aluminized Glass Overcover and NFPA approved Hazmat Boots. Wide-view lens.

Lakeland Industries offers the following NFPA approved pass-thrus:

- Option P1..... Scott-Hansen Pass-thru
- Option P2 Scott-Schraeder Pass-thru
- Option P3..... Standard Pass-thru
- Option P3SS Standard Pass-thru with stainless steel fittings
- Option P4..... Survivair® with Hansen® fittings
- Option P5..... Survivair® with Schrader® fittings
- Option P6..... Drager® with Hansen® fittings
- Option P7..... Drager® with Foster® fittings
- Option P8..... Drager® with Snap-Tite® fittings
- Option P9 MSA® dual purpose
- Option P6..... MSA® Wall-Thru unit
- Option G7 Quick Disconnect Glove System
- Option P11 Interspiro Pass-Thru

Lakeland Industries offers the following boots: Bata® Hazmat Boot, SEI Certified

Specifications – Aluminized Overcovers

Specifications and Component Descriptions for NFPA 1991, 2005 Edition Aluminized Overcovers

1. Garment Materials-are Aluminized Glass.
2. Suit design is to be worn only in conjunction with a approved Level A Chemical suit that accommodates a self contained breathing apparatus inside the suit.
3. All seams are stitched with Nomex® thread on the inside.
4. Closure is a 4” wide flap made out of the suit material; held in place with 1” black full-length velcro. Front Entry: starts at left side of hood front and across body. Rear Entry: center back.
5. Visor/Lens is 10 mil FEP Teflon® stitched in with Nomex® thread on the inside of the suit.
6. The head area is designed to accommodate a SCBA face piece and allow user to wear a hard cap or fireman’s helmet.
7. The optional pass-thrus; if purchased ; will be located in the right area to allow for hook-up of outside air for breathing and cooling. See “Style Identification” for more information.
8. Three valve covers designed to fit over the top of the Level A Chemical Suit exhaust valve system, 1-located on the right side of the back of the hood, 1-located on the right side of the expanded back, 1-located on the left side of the expanded back.
9. Color of the suit is silver.
10. The spacious sleeve is designed to fit in conjunction with the requirements of the Level A Chemical Suit.
11. For sizing see “Chemical Suit Size Charts”.

Methods of Attachment

Garment material	safety stitch
Visor material	single needle stitch
Glove material	N/A
Footwear material	N/A
Garment closure	single needle stitch
Attached overcover	N/A

Specifications – Level A

Specifications and component descriptions for NFPA 1991, 2005 Edition Chemical Suit

1. Suit fabric to be laminated film- Level A.
2. Suit Design- Expanded back to accommodate wearing of self contained breathing apparatus inside suit.
3. All seams stitched with 50/2 Permaspun® thread and sealed with specialized seam tape inside and out.
4. Zipper closure is a 48" PVC OEB design zipper with a vapor-proof closure by a 4" wide flap of suit material, and held in place by 5/8" full length velcro. Front Entry: left side of hood and across back. Rear entry: center back.
5. Visor/Lens materials- is a 40 mil PVC lens and a 10 mil FEP Teflon® lens sandwiched together using a specialized seam tape and process. This Visor/Lens is designed to ensure maximum visibility.
6. Head area-is designed large enough to accommodate a SCBA face piece and to be able to allow user to wear a hard cap or firemen's helmet.
7. The optional pass-thrus, if purchased, will be located in the right area to allow for hook-up to outside air for breathing and cooling.
8. Three exhaust valves designed to maintain a positive pressure in the suit when a breathing apparatus is in use are located as follows:
 - 1- on the right side of the back of the hood, 1- on the right side of the expanded back and 1- on the left side of the expanded back.
9. Gloves on NFPA 1991 certified ensembles are to be three separate components from inside out:
 - 10 mil Viton® Glove
 - North Silvershield®
 - Kevlar®
 - or "One Glove" System
10. The suit has attached sock boots with a splash guard to fit over industrial NFPA approved boots. Both sock boots and splash guards are constructed of Level A materials.
11. Color of the suit is lime green.
12. Spacious sleeve design allows wearer to have access to SCBA controls by pulling arm from sleeve while still in suit. The suit is designed to allow room for 2-way radio communication systems.
13. For sizes see "Chemical Suit Size Charts."
14. Suit to pass a minimum 180 minutes in NFPA 1991 Battery of Challenge Chemicals, see "NFPA Testing Results".
15. Suit must pass the ASTM F1052 pressure test.
16. Labeling in the suit contains the following: Warning Statement, Model Number, Serial Number, Date Manufactured, Pressure Test Results, an accompanying over boot style and marked if certified to optional chapters of the Standard.

	disconnect assembly
Footwear material.....	sock boot, single needle stitch, double sealed
Garment closure.....	single needle stitch, triple sealed
Attached overcover.....	attached at valve cover with Velcro®

►16

Methods of Attachment

- | | |
|-----------------------|---|
| Garment material..... | single needle, double sealed with seam tape |
| Visor material..... | single needle, triple sealed with seam tape |
| Glove material..... | ring and clamp assembly or quick- |

Chemical Suit Size Charts

Recommended Boot and Glove Size Chart – Chemical Suit Size versus Glove and Outer Boot Size

Suit Size	Boot Size	Glove Size
Extra Small – Medium	8-9	Large
Large	10-11	Large
Extra Large	12-13	Extra large
2 Extra Large	14-15	Extra Large

Lakeland Industries, Inc. Total Encapsulated Suit Height and Weight Chart

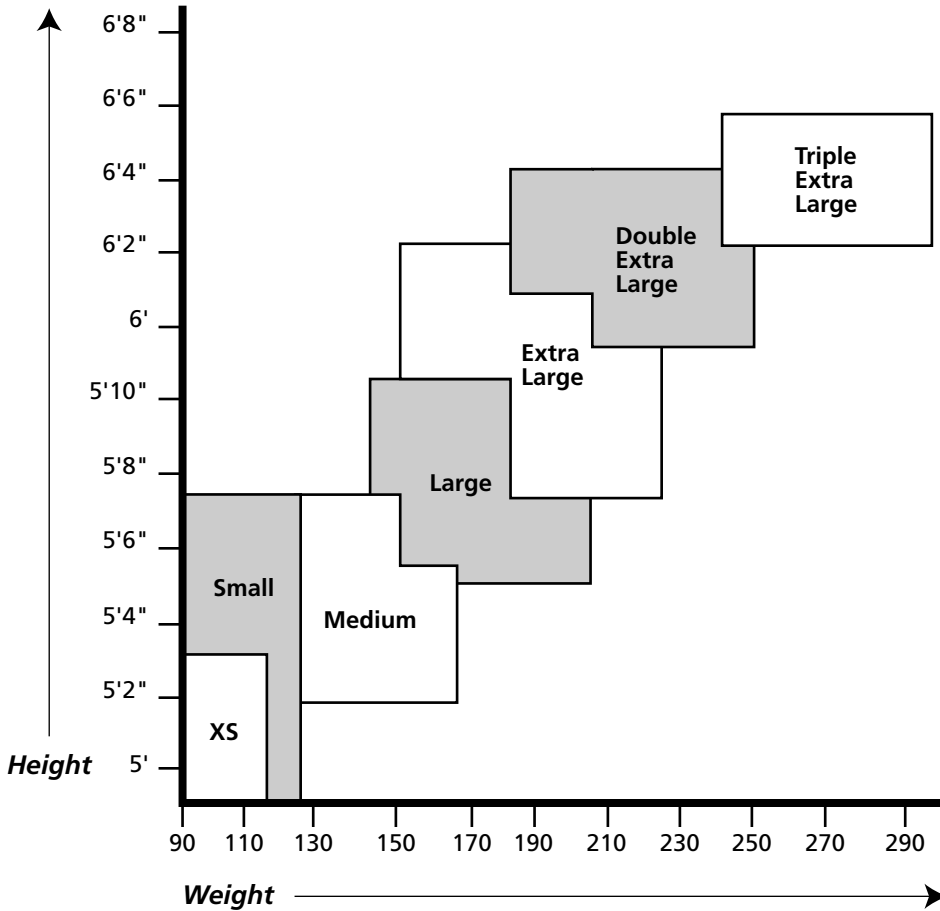

Note: If you are wearing structural fire-fighting gear, you may move up 1 size, depending on the restrictions of your gear.

This size chart accommodates use of SCBA, hard hats, communication devices and regular coveralls.

Height is in inches and weight is in pounds.

Note: See "Donning" for adjustment procedures.

Warnings and Limitations

This ensemble is not suitable for use in all situations and environments with all chemical and hazardous materials. All decisions regarding the choice and usage of chemical protective clothing must be done by trained and qualified safety professionals. It is the user's responsibility to determine the level of exposure and the proper personal protective equipment needed.

Lakeland chemical protective ensembles that are certified to NFPA 1991 require an over-cover. The protective over-cover provides additional protection against abrasion, cut, tear or puncture, and direct flame impingement. (All NFPA compliant Tychem® ensembles utilize specific, multiple glove combinations and specific boots. All components of the specified ensemble must be worn to be compliant with the requirements of this standard.)

►18

Lakeland chemical protective garments will burn. These garments should not be worn around heat, open flames, sparks or any other possible ignition source nor in potentially explosive or flammable environments.

If the Lakeland chemical protective garment is abraded, cut, torn, punctured or otherwise and in any way breached, do not use. The chemical protective garment material has finite resistance to abrasion, cut, tear and puncture.

If the Lakeland chemical protective garment is damaged during use, retreat immediately to a safe environment, thoroughly decontaminate the garment, then dispose of it in a safe manner.

LIMITATIONS OF USE

This ensemble is not intended for protection against radiological hazards.

This ensemble is not intended for protection from cryogenic liquids and gases (colder than -200° C). If there is a risk of exposure to liquefied gases warmer than -100° C, the use of an ensemble certified to the optional liquefied gas requirements of NFPA 1991 (2005 edition) should be considered. Note: It may be essential to protect the wearer from thermal transfer-related physical harm, such as frostbite, by providing the wearer with insulating undergarments.

CHEMICAL PERMEATION DATA

Before using a protective ensemble in a chemical situation, consult the chemical permeation data appropriate to the garment material. Note that seams, visors and closures will generally have lower or different permeation times than the garments' material. This information is to be used as a guide only. The permeation performance of any material depends on a number of factors including chemical concentration, temperature, time and amount of exposure. Due to the large number of variables, it is impossible for all ensemble materials to be tested against all chemicals, all combinations or mixtures, and all temperatures at which the chemical might be encountered.

Chemical permeation tests are performed under laboratory conditions -- not actual workplace conditions. They address chemical breakthrough characteristics and do not account for physical performance characteristics that affect a barrier such as abrasion, flex fatigue, puncture, tear, oxidative degradation, or degraded performance due to previous contamination.

No single protective material will protect against all chemicals for all situations. The best course of action is to test the primary protective garment materials against the specific chemical hazard, at the temperature and in the concentrations to be encountered. Lakeland Industries, Inc. will provide free swatches of primary garment materials for testing and can provide you with a list of testing facilities.

NEVER USE PURE OXYGEN

The use of 100% oxygen in this chemical protective ensemble presents serious fire safety and health hazards. Use only breathing quality, compressed air, air line supplied breathing air, or a rebreather system. Note that some rebreather systems utilize small oxygen cylinders, but these do not create enriched oxygen atmosphere.

MANAGE AND PREVENT HEAT STRESS

This garment interferes with the natural regulation of body temperature. This can lead to a rise in core body temperature and heat stress. The wearer should be aware of the symptoms and treatment of heat stress. The wearer can take several steps to limit and/or prevent heat stress, such as the use of a cooling system, and implementing a conservative work/rest schedule.

The maximum time the ensemble can be worn depends on such variables as the air supply, ambient condition, climate inside the ensemble, physical and psychological condition of the wearer, work rate and work load. The TLVTM pocket guide from the American Conference of Governmental Industrial Hygienists (ACGIH, Cincinnati) provides corrected heat stress limits for totally encapsulating garments. Similar information is available on the federal OSHA web site (www.OSHA.gov). The WBGT correction factor for chemical protective garments is at least 10° C or higher for totally encapsulating garments.

WEARERS MUST BE PHYSICALLY FIT

Ensembles should only be worn by persons who are in good physical condition. Working in chemical protective clothing is strenuous. In an emergency situation or hot environment, the wearer may experience heat stress. Persons who show symptoms of heat stress such as nausea, dizziness, high heart rates, or excessive heat build-up should leave the work area immediately and remove the ensemble as quickly as possible after decontamination. Persons in doubt about their physical condition should check with a physician before wearing chemical protective ensembles.

! ALWAYS USE THE BUDDY SYSTEM

Never enter a contaminated area alone. A minimum of two people should enter contaminated areas together. Two additional people, in equally protective garments should be available to assist rescue of the entry team. All persons entering the contaminated area should wear appropriate protective equipment.

! STATIC ELECTRICITY

Under certain conditions, such as cold and dry weather, it is possible that garments might build and discharge static electricity. Discharges are not normally dangerous except in situations where the generation of an electrical spark could ignite a flammable atmosphere or startle the wearer. When operating around flammable chemicals, steps to eliminate potential static discharges should be used. In these situations, steps have been recommended such as, but not limited to, water spray, the use of an over-cover, raising humidity level of the work area, use of a commercial, anti-static application coating, grounding straps on equipment and personnel, inherently static-dissipating under- and over-garments, and testing of the worker's static dissipation before entry into the classified area.

However, in the case of explosive or flammable atmospheres, even if sophisticated and elaborate steps are taken to manage static formation and dissipate static charge, the risk of severe injury remains if an uncontrolled or accidental ignition occurs. Lakeland chemical protective garments should not be worn in potentially flammable or explosive atmospheres.

! SOCK BOOTIES

The socks attached to chemical protective garments are designed to be worn inside outer boots. These sock boots do not have sufficient durability or slip resistance to be worn as outer boots.

! AVOID EXOTHERMIC REACTIONS

Certain chemicals produce a large amount of heat when they react with water. If garments are heavily contaminated with a water-reactive chemical, there is a possibility that the garment may be damaged during field decontamination from the high reactive heat. The excess chemical may have to be removed with dry sand or non-reactive absorbent before water decontamination.

! AVOID CONTINUOUS EXPOSURE

This ensemble should not be immersed in chemicals. This ensemble should not be exposed to continuous hazardous liquid chemical splash or deluge. Do not wade through liquid pools of hazardous chemicals if it is not necessary. Direct, liquid chemical exposure to the ensemble should be as limited as possible. If exposed to direct splash or a deluge of hazardous chemicals, leave the area immediately and decontaminate.

! SUPPLIED AIR LINE APPLICATIONS

To connect to an external supplied air-line system, encapsulating garments must be equipped with the appropriate, NIOSH approved garment pass-through. This passthrough connection should not be relied upon as an anchor for a tether. Excess pull on this fitting may result in permanent damage to the garment.

! AVOID SUFFOCATION

Do not attempt to wear a totally-encapsulating, chemical protective garment without supplied fresh air. This applies to vapor-protective (Level A) and totally encapsulating (Level B) garments. Air may be supplied to the wearer by a self-contained breathing apparatus (SCBA), supplied breathing air line, or rebreather system. Air-purifying respirators (APR) cannot be worn with totally-encapsulating vapor protective (Level A) or liquid protective (Level B) ensembles.

Air-purifying respirators (APR) cannot be worn under separate protective hoods that extend below the clavicle.

Powered air-purifying respirators (PAPR) cannot be worn with totally encapsulating vapor protective (Level A) or liquid protective (Level B) ensembles. PAPR's can be worn with ensembles utilizing separate hoods, if the configuration provides adequate ventilation at the intake of the unit and the unit is adequately protected from contamination.

! PROVIDE HEARING PROTECTION

If noise levels inside this ensemble exceed regulatory noise levels, hearing protection must be provided. Use hearing protection recommended by a safety professional which does not interfere with the operation or use of the garment.

! COMMUNICATIONS

A chemical protective garment hampers communication. The use of a personal communication system should be considered. Users should also consider the use of hand signals to communicate during training, work, and for emergency situations where respirators and chemical protective garments are worn.

! POSITIVE PRESSURE

Excessive, internal positive pressure can damage this vapor-protective garments. Do not inflate the vapor-protective garments above a pressure of 7 inches water column.

Level A Inspection Checklist

Purchased From: _____

Date Purchased: _____

Serial Number: _____

Style and Size: _____

Inspected By: _____

Inspected Date: _____

►21

Material	Check for any abrasions, holes, or tears.
Zipper	Check for overall condition, worn or damaged teeth, ease of operation. Lubricate zipper lightly with paraffin, which is readily available in most grocery stores. Paraffin should be applied lightly to the inner and outer elements. After cycling the fastener several times, the excess flakes should be removed. Do not use a sticky lubricant, which could gather and hold particles of dirt, grease, or contaminant. Garment should be stored with the fastener open.
Facepiece	Check that there are no splits, cracks, or deep scratches.
Gloves	Check glove integrity, PVC ring, quality of rubber bands, tightness of metal ring.
Exhalation valve	Check for freedom from obstructions and dirt; if replacement of valves are needed, send back to Lakeland for replacement.
Seams	Visually check for any split seams, tears, or separations of material.
Leak Test	Follow procedures out-lined under "Testing"
Log	Please mark log according to your findings. Date and sign, so that the status of the suit will be known at all times.

Test Kit Part Numbers

►22

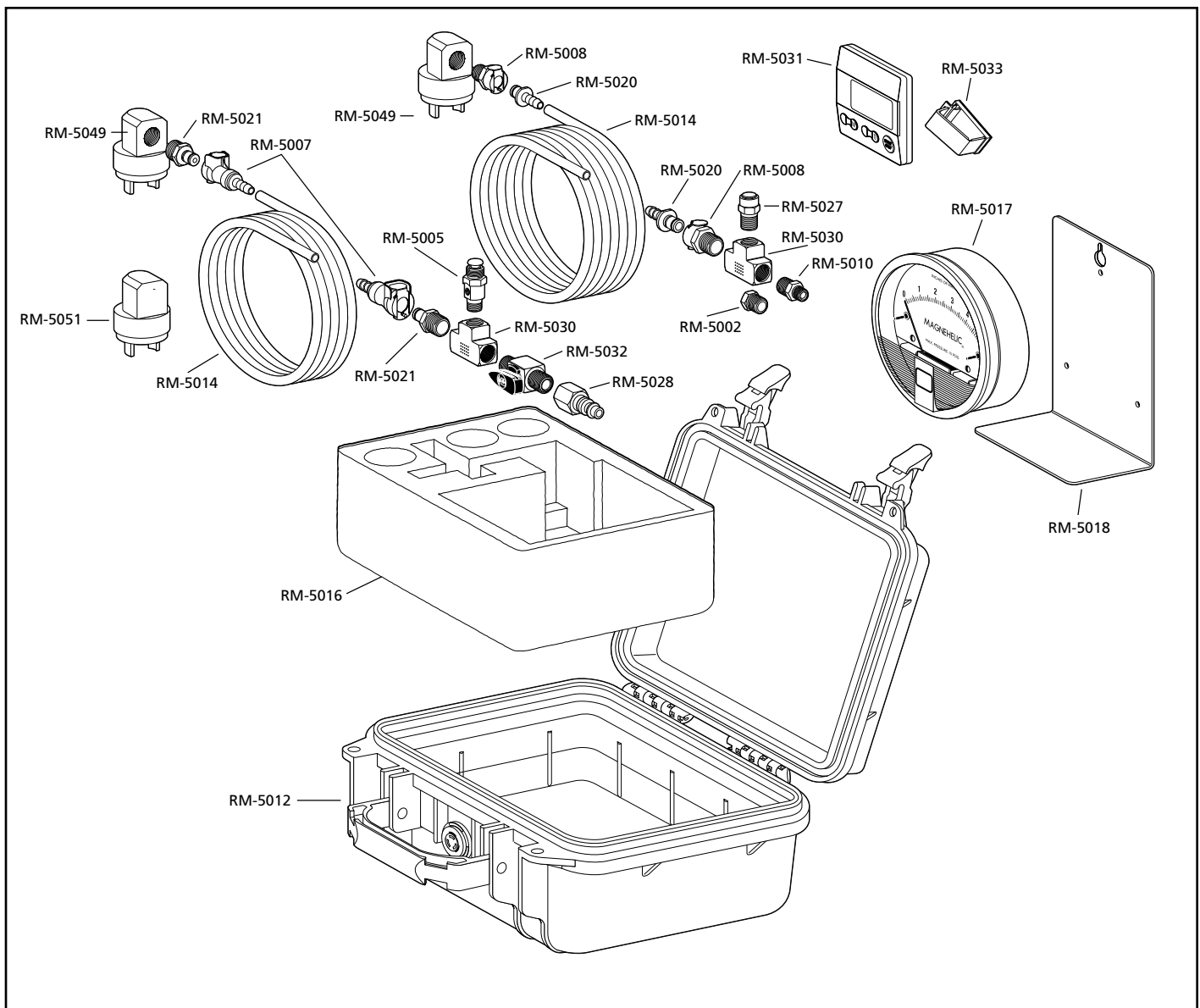

Part Number	Description	Part Number	Description
RM-5001	Brass quick disconnect 1/4" x 1/4"	RM-5021	Quick connect 1/4" with MPT
RM-5002	Brass reducer (female) 1/4" x 1/4"	RM-5022	Instruction sheet
RM-5003	Brass cross 1/4" FPT	RM-5023	Supplementary instruction sheet
RM-5004	Brass nipple 1/4"	RM-5024	Aluminum dump valve plug with 3/8" threaded hole
RM-5005	Brass Bleed Valve		
RM-5006	Black Max. Adhesive	RM-5027	1/2 lb. pop off valve
RM-5007	Quick connect 1/4" body w/barb, white	RM-5028	1/4" x 1/4" NPT hose connection
RM-5008	Quick connect with 1/4" MPT, white nylon	RM-5029	10 lb. pop off valve
RM-5009	Quick connect with 1/8" MPT, white nylon	RM-5030	1/4" brass tee female thread npt.
RM-5010	1/4"x1/8" Reducing Hex Nipple M x M	RM-5031	Alarm timer
RM-5011	Brass 1/4" pipe plug	RM-5032	Shut off valve
RM-5012	Test Kit Case	RM-5033	Flat wire holder
RM-5013	Test Kit exhaust valve plug	RM-5034	7/8" chair tip (dump valve plug)
RM-5014	Clear pvc tubing 3/16"	RM-5035	3/8" brass street elbow
RM-5016	Foam insert	RM-5036	3/8"x 3/8" plug coupler npt male conn
RM-5017	Magnehelic gauge	RM-5049	Dump valve plug with 1/4" ipt
RM-5018	A-369 gauge stand bracket	RM-5051	Dump valve plug
RM-5019	Rubber gaskets for plug (B.O.M.)		
RM-5020	Quick connect 1/4" insert w/barb		



Lakeland Industries, Inc.
Chemical Protective Clothing Division
202 Pride Lane SW
Decatur, AL 35603

Customer Service
Toll Free: 800-645-9291
Telephone: 256-584-3565
Fax: 256-350-3011
Email: sales@lakeland-ind.com
Internet: www.lakeland.com

Tychem[®], Kevlar[®], Teflon[®], Viton[®], and Nomex[®] are registered trademarks of the DuPont Company.
Silvershield[®] is a registered trademark of the North Company.
Tide[®] is a registered trademark of Proctor & Gamble.

2993/10/07/10M/Rev. 1.4

©2007